

Note that the first three questions are closely related to Lab 3. Be sure you save your calculations for the lab (remember you hand in the assignment just before you do the second half of the lab).

1. Solve for the loop filter transfer function  $F(s)$ , and use it to find the PLL transfer function  $(\theta_o/\theta_i)$  and the phase error transfer function  $(\epsilon/\theta_i)$  (in terms of R and C, etc, not  $F(s)$ ). Do not use any simplifying approximations for the loop filter until question 3.

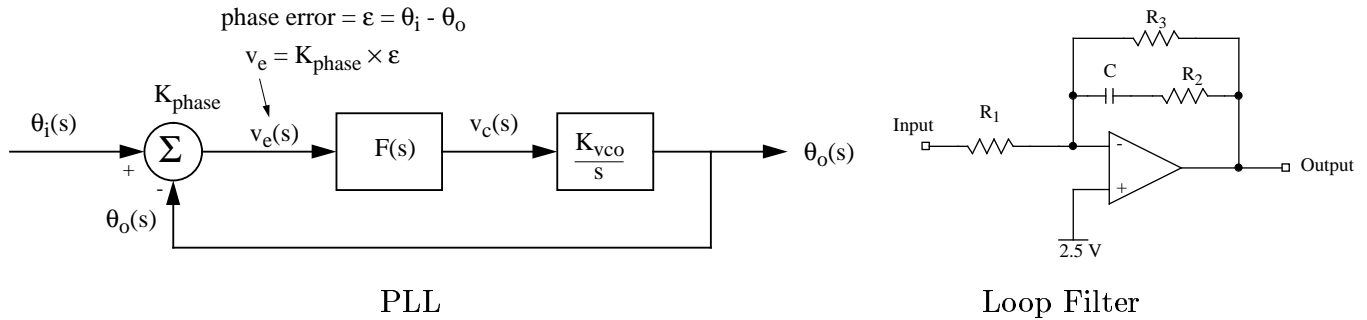

2. Now using the equations derived above, determine the values for the loop filter components such that the natural frequency of the feedback system is 2000 Hz and the damping coefficient is 1.0. Use a loop gain equal to  $2 \times K_{\text{phase}} K_{\text{vco}}$ . This means that your loop filter should have a gain of 2 at DC. You may choose to use your measured value for  $K_{\text{vco}}$  or  $K_{\text{vco}} = 2\pi \times 4 \times 10^5$  (rad/sec)/V which should be roughly what you measured. If you are using phase detector I, use  $K_{\text{phase}} = 1.6$  V/rad. For phase detector II use  $K_{\text{phase}} = 0.4$  V/rad.
3. For the above filter, determine under what conditions (components, frequencies) the simpler expressions as derived in class for the integrator and phase lead correction may be used. Does this apply to your component values?
4. Specify  $\omega_n$  and  $\zeta$  for a loop that will settle from a 50 kHz input frequency step in about 40  $\mu\text{s}$  (or less), with a maximum phase error during the transient of about  $45^\circ$  ( $\pi/4$  radians) (or less). The phase detector is an exclusive-or gate and the loop filter is an integrator with phase-lead correction. Sketch the approximate phase error versus time. Also, calculate the minimum frequency step which would cause the loop to lose lock during the transient.
5. We have a second-order loop with an integrator with phase-lead correction. The input signal to the loop  $f_i$  is a 1 MHz frequency modulated signal with a frequency deviation  $\Delta f$  of 800 Hz. As the modulating frequency  $f_m$  is changed we note that the maximum phase error  $\epsilon_p$  is 0.566 rad and occurs for a modulating frequency  $f_m = 1$  kHz. What is the damping constant  $\zeta$  and natural frequency  $\omega_n$  of the loop?

Note that for input modulating frequencies less than 1 kHz, the phase error is less than 0.566 rad. Now for the same  $\Delta f$ ,  $\omega_n$ , and  $\zeta$  as above, determine the input modulating frequency range (lower than 1 kHz) for which the phase error would be less than 0.25 radians.

6. A PLL synthesizer is required which generates frequencies from 19 MHz to 21 MHz in 500 kHz steps. Draw a block diagram of the synthesizer, label each part and determine what frequencies and (integer) divider values are needed. Assume a reference at 1 MHz is available.

If the 1 MHz reference now drifts in frequency by 1 kHz, what does this do to each of the 5 output frequencies?